

Heavy Duty Electronic Crane Scales

The SENS HS-X crane scale has a lightweight aluminum design that makes it genuinely portable and with a capacity range from 1 tons to 5 tons it is suitable for a wide variety of applications. The scale has a large bright red LED clearly visible from long distances, + a long life internal 6V/ah rechargeable battery

An infra-red remote control comes as standard and enables easy operation at a safe distance from the crane scale.

FEATURES:

- Aluminum Die-Casting Case
- Integrated load receptor
- Fixed shackle
- Standard eye hook
- LED module display
- Rechargeable battery
- Infra-red remote control
- Zero, Tare, Hold
- Battery supervision
- Overload alarm/record

SPECIFICATIONS:

SENS HS-X	Model Info.
Display	LED Module Display
Functions	Units Conversion, Hold, TARE, Zero, Total Accumulation, Calibration, Auto Zero, Auto Power off, Anti-Motion, illumination level, Gross & Net weight, Overload Alarm / record, Gravity Acceleration Set
Body Structure	Die-Casting Aluminum Case with Stainless Steel Shackle, Alloy Steel Rotatable Hook
Accuracy Class	OIML III Standard
Selectable Units	kilograms (kg), pounds (lb)
Overload	Over Load Protection and Alarm
Temperature Range	-10°C ~ +40°C
Battery	6V/4Ah (rechargeable) Battery life 80 Hours
Others	Infrared Remote Control and Adaptor DC9V

SENS HS-X

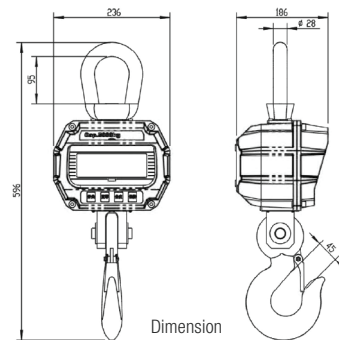

Capacity & Division	1 ton / 0.5 kg	2 ton / 1kg
	3 ton / 1 kg	5 ton / 2kg

Specifications are subject to change for improvement without prior notice.

