

MINI (For General Purpose) Electronic Crane Scales

This scale is a combination of the sound and proven mechanical design, with today's most advanced electronics to provide a superb feature set. It is versatile, reliable, accurate and easy to operate.

FEATURES:

- Mini HS-L Digital Hanging Scales for low capacities with Certified Quality System.
- Quality Stainless Steel load Receptor & Aluminum-casting Case for Better Safety.
- 20mm LCD, Visual Distance Over 10m and Dismount-able hook Design.
- SMT Technology, Quality integrated Circuit & Dedicated Weighing Load-cell,
- Ensures long Time Stability. 3*AA Battery with Low Power Consumption Design.
- Different Color Optional and Easy to Carry.
- Extended Warranty 3 Years



SPECIFICATIONS:

SENS HS-L	Model Info.
Display	0.7 inch (18mm) numerical
Face-Board	Water-Proof Panel with 5 keypad
Functions	Zero Tare In/Tare Out, Hold, Auto Power off Battery Supervision, Overload Alarm, Unit Switch
Accuracy Class	OIML III Standard
Tare Range	100% F. S. (Full Scale)
Zero Range	4% F. S.
Safe Overload	120% F. S.
Ultimate Overload	400% F. S.
Overload Alarm	100% F. S. +9e
Battery	AA (rechargeable) battery (130 Hours)
Temperature Range	-10°C ~ +40°C

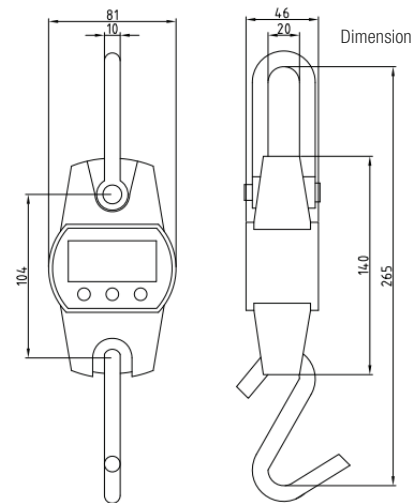

Capacity & Division	30 kg / 0.01kg	50 kg / 0.02kg	100 kg / 0.05kg
	150 kg / 0.05kg	200 kg / 0.01kg	300 kg / 0.01kg

